

# **DYNAMIC**

**ROLL LAMINATOR**

**OPERATION MANUAL**

**Please read this manual carefully before operation**

---

# CONGRATULATIONS

Thank you for purchasing and using our laminator.

You have purchased the finest laminator available in its service class. It was designed and manufactured to provide you with the utmost in utility. As with any device that combines power and movement in its use, there are dangers if improperly used. At the same time, there are easier and faster ways for getting the job done if certain precautions are taken first. Please read this manual carefully. It contains useful ideas in obtaining the most efficient operation from your laminator and safety procedures you need to know before beginning use. Save the manual for later use.

## CONTENTS

<b>SAFETY PRECAUTIONS</b> .....	3
<b>STRUCTURE AND CONTROL PANEL</b> .....	5
<b>INSTALLATION</b> .....	6
<b>FUNCTIONS OF DIGITAL DISPLAY, CONTROL PANEL AND EMERGENCY STOP</b> .....	7
<b>OPERATION INSTRUCTIONS</b>	
<b>PREPARATION</b> .....	10
<b>HOT LAMINATING</b> .....	12
<b>COLD LAMINATING</b> .....	13
<b>MAINTENANCE AND SERVICE</b> .....	13
<b>SPECIFICATION</b> .....	15

# SAFETY PRECAUTIONS



## WARNING

Please do not use broken , again or self-made electrical wire and damaged supply cord.

Please do not immoderately draw, twist or enlance the electrical wire, to avoid the fire or electric shock.



## NO DISJOINT

Don't disjoint, modify and repair the machine, if there are any problems on the machine, please do not use it, send it to the dealer for repairing.



## ENTANGLEMENT CAUTION

Keep hands, long hair, loose clothing and articles like ties or necklaces away from the rollers to avoid entanglement.

In case some articles entangled, press the emergency stop button immediately; if not workable, cut off the power supply at once, and contact your dealer for settlement.



## ELECTRIC SHOCK CAUTION

Do not make the electric wire or plug or the machine bedewed by water or other liquids.

Do not operate the machine with wet hand.

Do not make the machine pressing on the electrical wire. .

Do cut off the power supply while moving the machine.

Do not operate the machine with cover open.



## HIGH TEMPERATURE CAUTION

Do not put articles on the laminator while it is working, so that to disperse the heat.

Do not insert the easy-burnt or easy-softened material into the machine, in case they are melting and give rise to smoke.

Do not touch the cover, heating roller and heating parts while the machine is working, in case heat injury.

# SAFETY PRECAUTIONS



## WORKING PLACE

This machine should be put at the dry and clean place, do not put it at the damp place or near the exit of cooling appliances.

This machine should be put on the horizontal and firm place. In front and rear the machine there should be sufficient place for the document in and out.

Do not put any articles on the machine.

## LAMINATING FILM

Please use good quality laminating film in order to show the lamination effect, and avoid the entanglement.

## OBJECT

The laminating machine use the hot press technology, do not use the following objects in case laminating failure or laminating film entangle.

1. Easy-burnt material, easy-softened material
2. The document printed by heat-sensitive paper, or any articles that can be faded or transformed after heating.
3. Any articles that have drape, breakage, dampness or deformation before laminating.
4. Coin or any other hard articles.

**\*Means exception while cold laminating operation.**

Do not laminate articles that exceed total recommend material thickness.

## MACHINE OPERATION

Do not turn to other usages except the usage range stated in this operation manual.

Do not use the machine outside the room. Before leaving, please cut off the power supply if the operation is over.

Read all safety messages located in this manual and on the machine very carefully.

## ADVICES

While operating the machine, mind the children nearby, in case any suddenness.

Do not suspend the electrical wire on the table or any other places that the children can touch, or place easy stumble persons.

Using the accessory that not recommended or sold by the manufacture, might cause damage on the machine.

The photo or document once is laminated it will became permanent and will not be taken apart.

Please do not laminate the collected rare articles, or some articles might be taken out in the future.

360-650

### STRUCTURE AND CONTROL PANEL

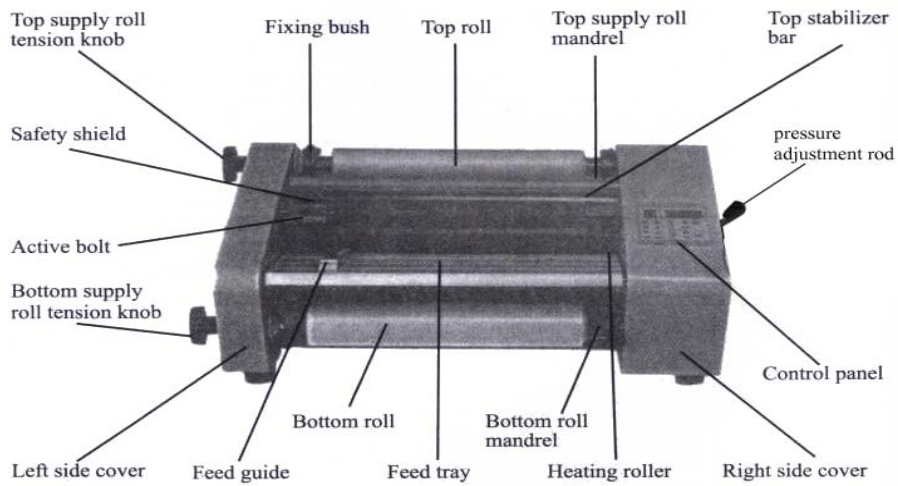

1100

### STRUCTURE AND CONTROL PANEL

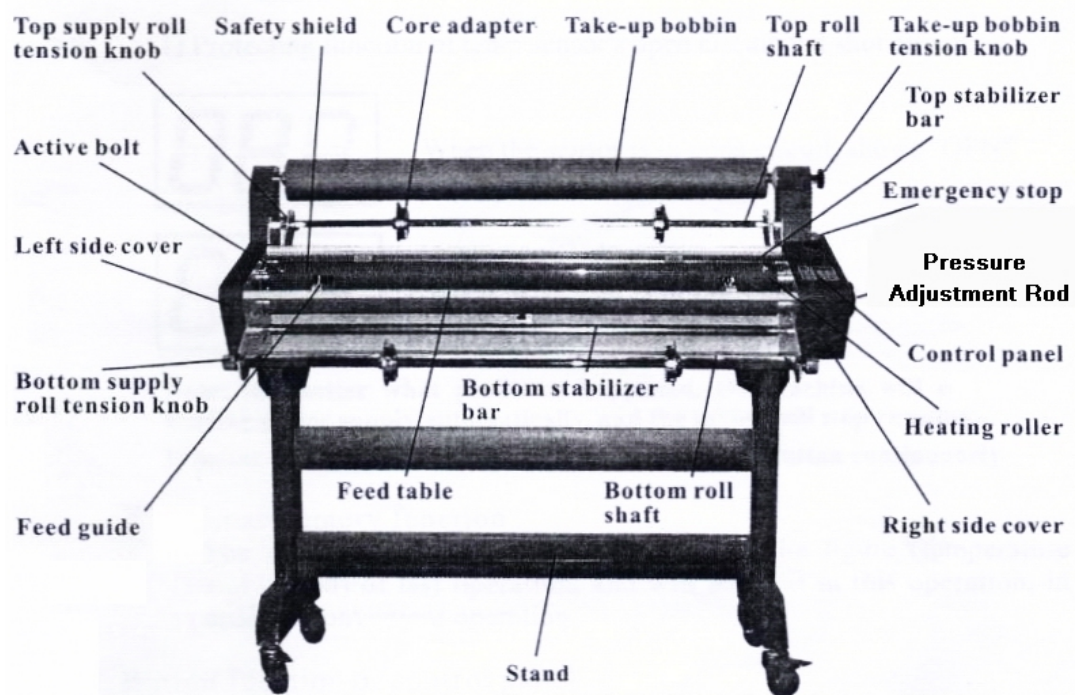

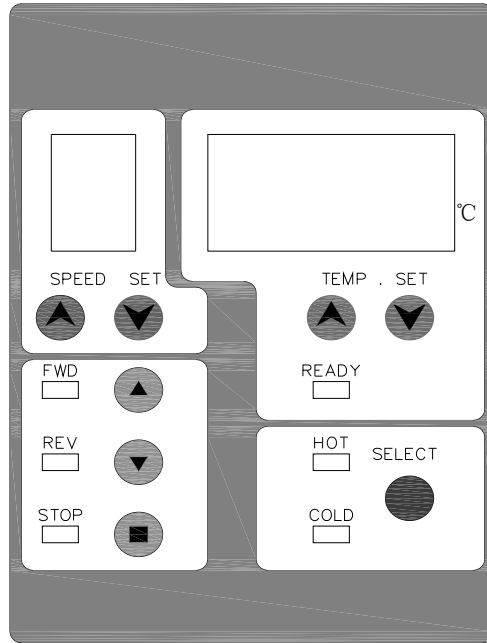

## INSTALLATION

1. Upon receipt of the laminator, inspect of box, the machine and all other contents of the box for shipping damage. Shipping damage should be brought to the immediate attention of the delivering carrier.

**WARNING:** the four nuts on the top of wooden case are used for fixing the machine stand inside the case. While disassembling the case, do take out the fixing nail which connect the top cover and the bottom base **FIRST**, then remove he top cover, open the wooden case. **LAST**, unscrew the bolt and take out the machine stand. **DO NOT** loosen the fixing bolt before open the wooden case, in case the inside machine stand drop onto the machine and damage it. The supporting beams are inside the box.

2. The laminator comes fully assembled on a stand.
3. Screw the wheel on the stand, put the stand upright. Place the middle supporting beam horizontally, connect the beam and stand with the bolt which has spring washer on it, then fasten it.

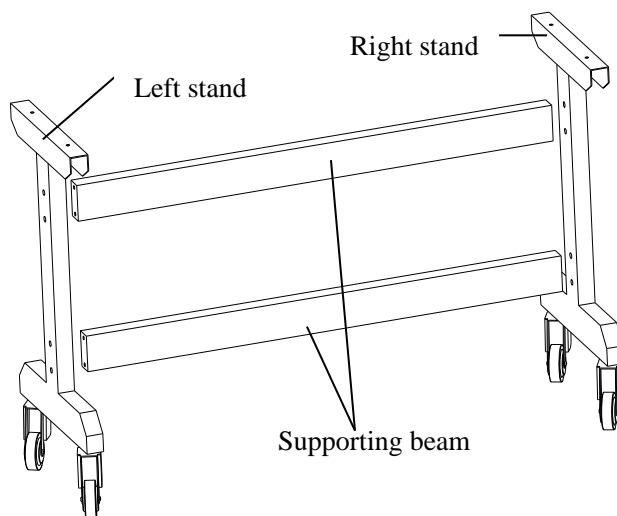

2. Put the laminator on the assembled stand.
3. Start operation after turning the wheel stop switch to “OFF”.

## FUNCTIONS OF DIGITAL DISPLAY, CONTROL PANEL, MURGENCY STOP, PRESSURE ADJUSTMENT ROAD AND CUTTER

1. Digital display and functions
  - 1) Protecting function of temp sensor's open circuit and shot circuit.

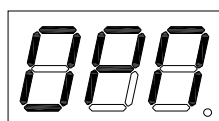

When the sensor is open circuit, shows “OPN”.

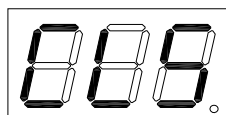

When the sensor is in short circuit, shows “CLS”.

**NOTE: No matter what problems happened, the machine will cut off the heating power supply automatically, and the motor will stop running. If motor running required, press the FWD or REV Button continuously.**

- 2) Auto memory function

The machine will automatically remember the figure (temperature and speed) of last operation, and will adopt it in this operation, in order to convenient operation.

## 2. Button function of control panel

### 1) Temperature control

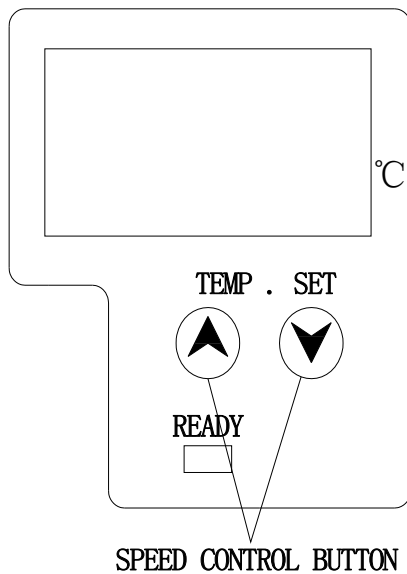

A) These can be used for increasing or decreasing temp manually. The temp can be increased or decreased by 1°C when these buttons are pressed. Pressing the button, the temp will be increased or decreased continuously until you loose the button.

B) The range of temp that can be adjusted manually is 0--150°C.

C) When the temp reach 150°C, the over-heat protecting system will run automatically.

D) When pressing the temp control button, it indicates the setting temp, when losing the button for seconds, it indicates the present temp automatically.

E) When the setting temp is reached, the READY lamp is light.

### 2) Speed control

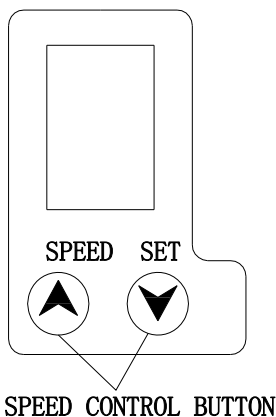

A) These buttons can be used for increasing or decreasing speed manually. The speed can be increased or decreased by until to 1 speed when these buttons are pressed.

B) The range of speed that can be adjusted manually is speed 1-9.

### 3) Forward, Reverse and Stop control

Press FWD or REV or STOP button can change the working condition of the machine.

A) Motor runs forward, the laminating film in, the machine works.

B) Motor runs reverse, the laminating film out. This function is used for remove the object inserted by mistake.

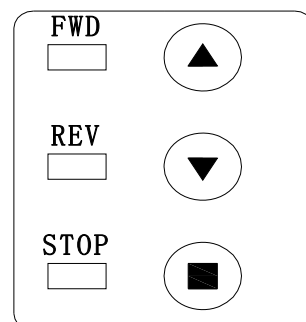

C) Motor stop. This function is used for standby.

#### 4) Function selection

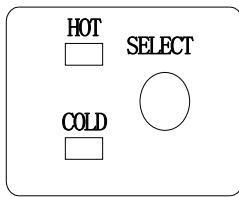

A) Press the SELECT button to change the function of machine between hot and cold lamination.

B) While the HOT lamp is light, the machine is on hot laminating.

C) While the COLD lamp is light, the machine is on cold laminating.

#### 3. Emergency stop



There is an emergency situation pressing the button will stop the rollers and stop heating. Rotate the button to the direction of arrow to turn on the power supply.

#### 4. Pressure Adjustment Rod

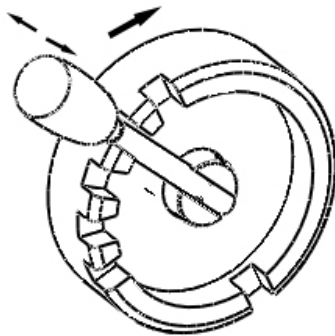

Pressure adjustment rod is a part to adjust the up and down roller distance. Adjust the rod to different positions to change roller pressure.

Get the rod out of the gear, rotate it clockwise or anticlockwise, then put the rod into the gear while reach the required pressure.

Rotate clockwise is increase roller pressure; rotate anticlockwise to reduce roller pressure.

#### 5. Cutter

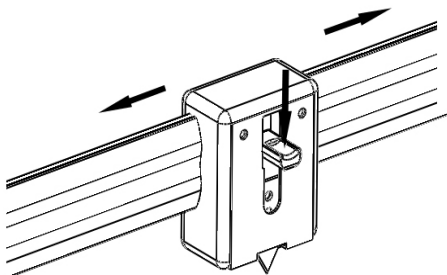

Cutter is a part to cut off the laminated object from the film. Please press down the button then move the cutter to the sides to cut off the film.

# OPERATION INSTRUCTIONS

## PREPARATION

1. Connecting the power source
  - 1) Checking the rated voltage on the machine, to insure it conform to the power source. Also, checking the plug to insure it conform to the socket.
  - 2) Insert the plug into the power socket that is grounding correct.
  - 3) Turn on the power switch, the display light, it indicates the power is connected.
  - 4) The fuse is installed on the under of the machine.

## 2. Film threading

### HOT FILM

Step 1: Raising the safety shield.

Step 2: Taking out the feed table.

Remove the active bolt under the feed table, take out the feed table.

**Remark: the machine will power off when the safety shield and the feed table are not in their proper positions.**

Step 3: Follow the diagram to thread the film.

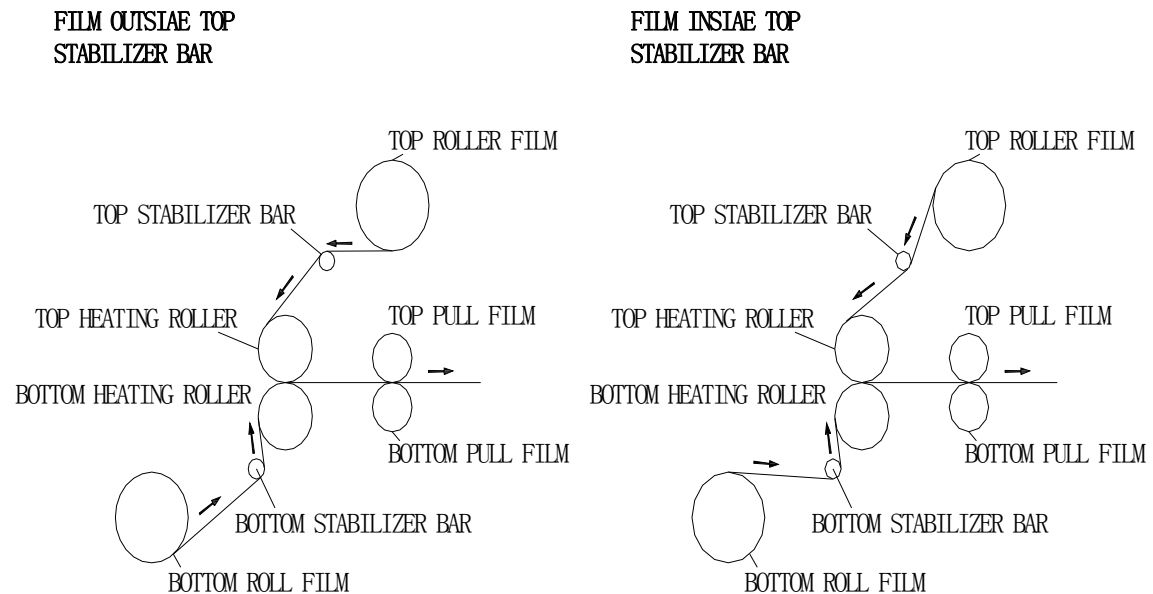

# OPERATION INSTRUCTIONS

**Remark: Usually the shiny side is the polyester side, it contact the roller.**

**The dull side is coated with adhesive. For the matted film, the two sides have minor difference, please especially be careful. Heat the film with lighter can easily tell the polyester side and adhesive side. The adhesive side must face away against to the roller.**

Slide the roll film onto the roll shaft (follow the above instruction, do not load the film in wrong side). Hold the roll film on the core adapter, the core adapter can hold the core of the roll film, to prevent it rotating. Screwing the bolt on the core adapter put the rolls on the brackets. Make sure it is fully seated.

**Caution: For hot laminating, the top and bottom roll film must have same width; besides, the top film and bottom film must be aligned. (If the film is not in alignment, loose the bolt on core adapter and align it.)**

Step 4: With both roll films threaded and installed in their respective brackets, unwind the top and bottom supply rolls about half-turn each. This will provide enough slack in the web to allow the feed table to slide on easily.

Step 5: Slide the feed table into position and lock the active bolt.

Step 6: Position the safety shield forward toward the roller and lock the active bolt.

**Remark: the machine will not power on without the feed table and the safety shield in the proper positions.**

Step 7: Make sure there is still enough slack in the web. Close the rollers with the knob on the right side of the laminator. With film draped over the two heating rollers, and melted or taped together, push one edge of the threading card between the heating rollers so that the film is firmly positioned. Make sure the rollers are in closed position, if a threading card is not available, any piece of card stock or poster board will work.

## OPERATION INSTRUCTIONS

Step 8: Push the FWD button. If the film and the card are in the nip (the point where the top and bottom roller meet), the film and the threading card will start into the laminator and will pass through both sets of rubber rollers. When the threading card has cleared the back of the machine press the **STOP** button

**Caution: For operator safety, the safety shield must be in position over the upper heating roller when the machine is ON, or the FWD button is pressed.**

### **COLD FILM (1100)**

Step 1: Raising the safety shield.

Remove the active bolt on the shield, raise the safety shield.

Step 2: Follow the diagram to thread the film.

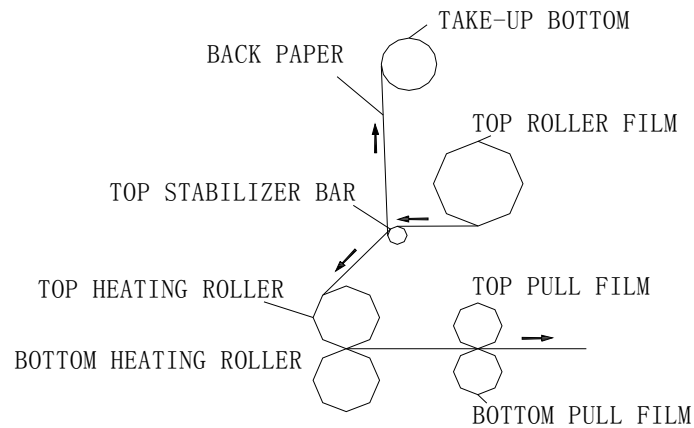

Slide the roll film onto the roll shaft (follow the above instruction, do not load the film in wrong side). Hold the roll film on the core adapter, the core adapter can hold the core of the roll film, to prevent it rotating. Screwing the bolt on the core adapter put the rolls on the brackets. Make sure it is fully seated.

Step 3: Insert a piece of wide cardboard (guiding paper) between the rollers. The width of cardboard should be larger than the width of cold film. Pull the film from the top roller passing over the top stabilizer bar to the top roller.

Step 4: Put the paper back of the cold film to the bobbin at take-up bar to rewind the paper back. Allow some of the cold film with melted resin to stick the wide cardboard (guiding paper).

Step 5: Position the safety shield forward toward the roller and lock the active bolt.

**Remark: the machine will not power on without the safety shield in the proper positions.**

Step 6: Close the rollers with the knob on the right side of the laminator. Push the FWD button. The films will be fed into the machine. Check the status of lamination.

### **HOT LAMINATING**

1. Turn on the machine, press the SELECT button until the HOT lamp is light, the machine begin heating. Set the temperature for whatever film is being used.
2. The laminator will be ready to operation in about 20 minutes

#### 1) Trial lamination

If the roll film is the first time to be used, the trial lamination is required for perfect result. After the READY lamp is light, close the rollers with the pressure adjustment rod on the right side of the laminator, press FWD button, let at least 250mic of film go through the rollers before inserting the items to be laminated. Examine the perfect lamination result.

**Remember: This machine has auto memory function that means if you work on the same roll, after the machine is switch on, the temperature and speed will be set to the same figure of the last operation before it was switch off. You can start lamination work directly.**

- 2) After the trial lamination has a satisfied result, position the feed guides according to the width of the item to be laminated, entering the item in the web of film.

**Remind: keep clear and enough space behind the machine; so that the laminated item can come out easily, it will not wind onto the rubber roller. If the machine is stopped for a long period, set the temperature decreased by 5-10°C, this will prolong the work-life of the machine.**

Stop the machine after the item to be laminated pass through the roller completely, otherwise there will be an imprint on the item.

### **Temperature setting**

Normally, your film supplier should provide the information about the film application temperature and operating characteristics. If you do not know the source of your film, or if the supplier can not provide the information, please try the temperature and speed until you have the best result.

**Caution: If you do not know the source of the film, or if the supplier can not provide the information, do not set the temperature more than 130°C.**

### **COLD LAMINATING**

1. Press the SELECT button until the COLD lamp is light, load the cold film.

**Caution: The adhesive side must face away from the roller.**

2. Set the proper film tension by the top roll tension knob, set the speed at level 2 or 3.

3. Put the document on the feed table. Turn on the take-up motor switch and the FWD button at the same time. The liner and film will be rolled at the same time.

**Remind: The width of document should be larger than the width of cold film. If the width of document is smaller than the width of cold film, please put a protection paper under the document(the width of paper should be larger than the width of cold film).Otherwise, glue from the film will be stuck on the face of roller and it can be seriously damaged.**

3. Stop the machine after the document to be laminated pass through the roller completely, otherwise there will be an imprint on the document.

## **MAINTENANCE AND SERVICE**

### **GENERAL MAINTENANCE**

Do not laminate the metal or other hard items in case the damage of the rubber rollers.

While stop the laminating, lift the top rubber roller with the pressure adjustment rod on the right side of the machine. Do not press the rubber roller in case the rubber become stiff and thus shorten its work-life.

Cleaning the machine timely will help prevent dirt or adhesive build-up on the rubber rollers and will improve the performance of the unit.

### **CLEANING THE RUBBER ROLLERS**

During the normal lamination, excess adhesives from the film will often cling to the rubber rollers.

To clean the rubber rollers, lift the rubber roller, remove the film from the machine

first, heat up the machine to 30–40°C. The warm roller enable it easier to remove the adhesive built-up on the rollers.

Raise the safety shield and take out the feed table. Using a clean, soft, ethanol dampened cloth, gently rub the adhesive off the rollers.

**Caution: Never use any abrasive or sharp metal material or rub too hard on the roller, because you may damage the rubber surface.**

### **MAINTENANCE AND SERVICE**

Press FWD or REV Button, the roller will run, cleans the roller. After cleaning, position the feed table and slide on the safety shield.

**Caution: if the film gets wrapped around the roller, press STOP button (stop heating) immediately. Warning: do not use any cleaning solution to clean the roller, because some solution may burn on the hot roller. After the roller cool down, cut the film on the top and bottom, just in front of the stabilizer bars. Reverse the roller at a very low speed and allow the machine to back out the film that is wrapped around the rolls, pull the film off the roller. Clean the adhesive on the roller.**

### **PROBLEM SOLUTION**

**Please read this section before you have a problem**

**PROBLEM:** No power is getting to the machine.

**SOLUTION:** Make sure there is power at the electrical outlet being used, and make sure both ends of the power cord are firmly engaged. There are fuses inside the laminator, but dead outlets and loose power cord connections are the most common causes this problem.

**PROBLEM:** Wrinkling of the film around the material being laminated.

**SOLUTION:** This is normal and inevitable on any laminator, especially with thicker material. These wrinkles will be trimmed away with the scrap, so they do not affect appearance. Because the rollers are being held apart by the paper, they cannot pull equally on the plastic around the paper. This creates wrinkles that tend to look like the bow waves of a boat, radiating out through the clear part of the web from the sheet of material.

**PROBLEM:** When two pieces of material are laminated side by side, the plastic adhesive to one piece but not the other.

**SOLUTION:** To get maximum efficiency from the film rolls, you can feed several items into the laminator side by side. However, wrinkling can occur if these items are of unequal thickness,

because the laminating rollers are lifted off the thinner items by the thicker items. When laminating items side by side, it is important to arrange them so that the thickness is the same.

**PROBLEM:** Film gets wrapped around the laminating rollers while hot laminating.

**SOLUTION:** The film is threaded improperly. If the adhesive side faces to the roller, the film will be wrapped around the rollers. Thread the film in proper position.

The laminating temperature is too high, the film will be melted and wrapped around the rollers. Decrease the laminating temperature.

Press the STOP button immediately. After the roller cool down, cut the film on the top and bottom, just in front of the stabilizer bars. Reverse the roller at a very low speed and allow the machine to back out the film that is wrapped around the rollers.

**PROBLEM:** Wrinkling of the plastic on a laminated material.

**SOLUTION:** Check the tension of the film, make sure the film is threaded properly (see film threading).

**PROBLEM:** Film is not properly adhered.

**SOLUTION:** The laminating temperature is too low; there is not enough heat for melting the adhesive. Increase the laminating temperature.

**PROBLEM:** The laminated material seems to have an irregular surface that does not match the texture of the paper being coated.

**SOLUTION:** This is usually caused by adhesive build-up or dirt on the rubber rollers. Inspect the rubber rollers and clean it.

Damages to the rubbers can also cause irregularities in the surface of the film.

**PROBLEM:** General haziness or cloudiness in the film after lamination.

**SOLUTION:** Increase the temperature or decrease the speed. That cloudiness is a function of incomplete adhesion. On a variable speed machine loaded with thicker film, it may be that the film is being run too fast.

For problems not listed here, contact your local dealer.

## **SERVICE**

If the service is required, please provide the following information:

The detail of the problem

Installation Date

Serial number

# DYNAMIC Roll Laminator

## SPECIFICATIONS:

MODEL	360R	480R	650R	1100R
Operate mode	Electric			
Max.laminating width	360mm	480mm	650mm	1070mm
Max.laminating thickness	3mm	3mm	3mm	2mm
Max.laminating temperature	150°C	150°C	150°C	150°C
Max.laminating speed	0.3-2.5 m/min	0.3-2.5 m/min	0.5-3.2m/min	0.6-4 m/min
Recommended film	Up to 250mic			
Diameter of heating roller	44mm	44mm	55mm	75mm
Diameter of pull roller	30mm	30mm	45mm	55mm
Roller quantity	4			
Heating system	Hot roller			
Power supply	AC 220, 50Hz			
Power consumption	1000W	1200W	1500W	2500W
Dimension (MM)	645x435x270	765x435x270	990x435x300	1350x600x1200
Weight	28KG	34KG	41KG	155KG

Sales & Service Center :

Website : [www.taruna-jaya.com](http://www.taruna-jaya.com)

Email : [support@taruna-jaya.com](mailto:support@taruna-jaya.com)